

**INSTRUCTION GUIDE**  
**INSTALLATION of the Wz.88 POLISH TANTAL optical rail**  
**Made by AK-BUILDER.COM**

**INTRODUCTION:** The AK-BUILDER.COM optic rail you have purchased is designed to mount onto Polish Ws. 88 stamped receiver Kalashnikov rifles. This rail system has an overlapping plate design that allows you to retain the original left side auxiliary selector lever found on military Wz. 88, 89, and 96 model rifles. We have slightly modified our mounting plate from a replica of the rare original Polish military design. These were created for the attachment of heavy Soviet based night vision devices. It is the most secure method for attaching optical devices to Kalashnikov-type rifles, and allows the correct positioning of quick detachable optics, military and commercial, with total retention of zero. This is a CNC machined replica made from high quality steel, then black oxide. This rail may be attached using mild steel rivets, machine screws, or welded into place.

**DISCLAIMER:** AK-BUILDER.COM cannot control the conditions under which these products are used. We cannot be responsible for any damage to, misalignment of, improper use of the product, guide, or of the rifle it is used on. This installation guide was written exclusively for self-help guidance, and cannot be considered as a complete authoritative manual for professional installation. However, we have done our best to make sure it is as accurate as possible and describes how an average individual can do this procedure with professional results. Please feel free to deviate as necessary for your personal needs and custom applications.

**SKILL LEVEL REQUIREMENTS:** If you read these instructions and determine you are not fully capable of doing this installation, please consult a gunsmith or machinist. Care must be used to make sure you do not damage/mar your rifle.

**SAFETY:** It is the responsibility of the installer to make sure standard safety procedures are followed during installation. Make sure your firearm is **UNLOADED** before attempting any maintenance actions. Wear personal protective clothing such as gloves and goggles when drilling, cutting materials, or pressing rivets. Follow general shop safety rules when using hand or power tools. Any personal injury or property damage caused by or during the installation is not the responsibility of the rail manufacturer or supplier.



KIT CONTENTS	QUANTITY
anchor plate	1
dovetail plate	1
#10-32 x 1/4" long button head screw	2
#10-32 x 5/16" long button head screw	1
1/8" allen hex key	1
#16 drill bit	1
#21 drill bit	1
13/64 drill bit	1
#10-32 hand tap	1
13mm long swell neck rivet	1
#10-32 x 1/2 machine screw	3
extended center support	1
1mm center support tube	1
extended length rear trunnion rivet	1

TOOLS NEEDED
dremel / die grinder / belt sander
1" c-clamp or vise grips
bench top drill press (recommended) or hand drill
standard "flat" screwdriver
hydraulic press for riveting (for rivet assembly)
ak-builder.com rivet tool (for rivet assembly)
tap handle (for screw assembly)

**RAIL OVERVIEW:** The two piece design, allows the retention and use of the standard left side receiver-mounted auxiliary lever. The anchor plate is permanently riveted, screwed, or welded to the rifle while the dovetail plate is screwed and aligned onto the anchor plate. All rivet head locations are made flush with the top surface of the anchor plate and are normally impossible to see in original images on these rifles in the field. The AK-BUILDER.COM rail system is a modified copy of other rail mounts no longer available. We have made the anchor plate mount more versatile to the builder whether mounting to the receiver on a new build or adding the plate to a completed rifle. This rail system will work for either fixed stock or wire sidefolder Polish Tantal Wz. 88.

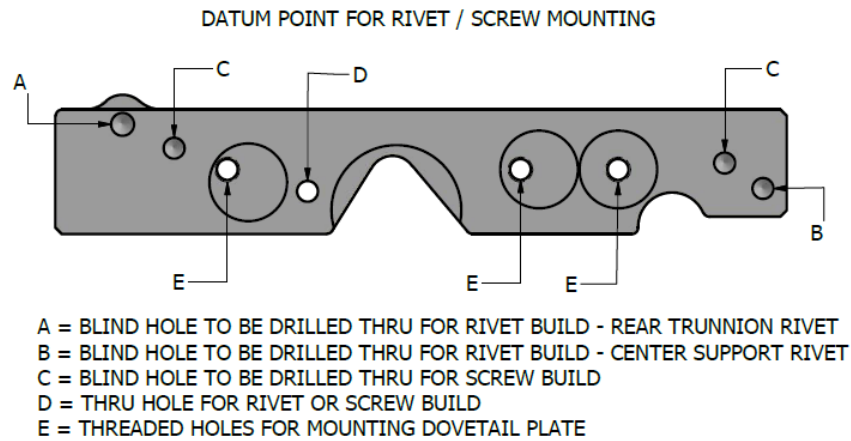

*Figure 1 : anchor plate inside view closest to receiver*

**BEFORE YOU BUILD:**

The builder must first decide if they want to attach the adapter plate with screws or rivets. This decision may also be determined by two factors.

- 1) Is the rifle already a complete build and the builder is just adding the rail system.
- 2) The rifle has not been built yet. It is a "kit" and the rear trunnion along with the center support rivets have not been formed to a bent receiver.

If the builder prefers to rivet the adaptor plate to a finished receiver, they will first need to de-mill the finished receiver by drilling out and removing the center support rivet and the furthestmost rear rivet on the rear trunnion. Please read both of the mounting instructions (option 1 = riveting / option 2 = screw) thoroughly before continuing to determine how you will be attaching the anchor plate to the receiver.

**OPTION 1 (RIVETING METHOD):**

- 1) Finish drilling datum "A" thru with the #16 drill bit supplied.
- 2) Finish drilling datum "B" thru with the #21 drill bit supplied.
- 3) The forward rivet head on the rear trunnion must be ground slightly to allow the plate to sit flat against the receiver. (for step 3 see figure: 2)



*figure: 2 ground trunnion rivet for clearance*

**OPTION 1 (RIVETING METHOD– continued):**

**4)** After grinding the forward rivet on the rear trunnion, lay the anchor plate over the left side of the receiver and align the rear trunnion rivet hole with datum “A” and insert rivet thru. Next, align the center support hole with datum “B” and insert rivet thru. **DO NOT PRESS RIVETS YET**

**5)** With both rivets holding the anchor plate in place, use the plate as a drilling guide and drill datum “D” thru the receiver using the #21 drill bit supplied.

**6)** Remove the plate and use a countersink to chamfer the outside of the plate at datum “A, B, & D”. This will give the rivet area to fill so that later the builder can sand the rivet heads flush with the plate.

**7)** Re-align the anchor plate with the receiver following step “4” above.

(for steps 4, 5, 6, 7 see figure: 3)



*Figure : 3 drilled and countersunk datums “A”, “B”, “D”  
Drilled datum “D” thru receiver*

**8)** Using a 1” c-clamp or vise grips to hold the anchor plate in place, press the center support rivet and rear trunnion rivet.

**9)** Insert the small rivet supplied thru datum “D” from the outside. Press the rivet forming the head inside the receiver.  
(for steps 8, 9 see figure: 4)



*Figure: 4 press rivet heads*

**OPTION 1 (RIVETING METHOD – continued):**

**10)** Use a die grinder or dremel tool to sand the rivet head of datum “D” flush with the surface of the anchor plate. This must be done so that the dovetail plate lays flat against the anchor plate. It is not necessary, but the builder may also grind the rivet heads from datum “A & B” flush with the plate as well. This will give it more of an “original” look. (for step 10 see figure : 5)



*Figure : 5 grind datum “D” head flush with anchor plate*

**11)** Finally, lay the dovetail plate on top of the anchor plate and align the datum “E” threaded holes. Tighten the dovetail plate to the anchor plate using the three #10-32 machine screws supplied in the assembly kit. If there is any touchup work that needs to be done, now is the time. Once the builder is happy with how the mount lays out we suggest using Loctite on the threads and “ping” a small divot on the screw heads using a center punch to keep them from backing off. (see figure : 6)



*Figure : 6 center punched screw heads*



*Full assembly with optical mount installed*

## OPTION 2 (SCREW BUILD):

**1a)** Using a 5/16 inch drill bit (not included), counter drill datum "A" on the anchor plate to the depth of the spotted hole on the inner side. Repeat for datum "B" using a 9/32 inch drill bit (not included). These holes have been predrilled to a depth, but not thru the outside of the mount. **DO NOT DRILL THRU.** This is so the anchor plate will sit flush with the receiver that has been completed. The rivet heads from the center support and rear trunnion will fit inside the spotted holes and not be seen from the outside.

**1b)** Drill thru the anchor plate datum holes "C" (2x) and "D" using the #21 drill bit supplied.  
(for step 1a & 1b see figure: 8)



Figure: 8 counter drill holes for rivet heads and drill thru anchor plate at datum "C" (2x) & "D"

**2)** The forward rivet head on the rear trunnion must be ground slightly to allow the plate to sit flat against the receiver.  
(for step 2 see figure: 9)



figure : 9 ground trunnion rivet for clearance

**3)** Lay the anchor plate over the left side of the receiver. Be sure the plate lays flat against the receiver and the rivet heads sit into the counter drilled holes. If it does not align due to the rivet heads not fitting into the drilled holes move up in drill sizes and repeat step 1 (option 2 screw build). The ground rivet head in step 2 of "option 2 screw build" may need to be ground further if it is hitting on the inner portion of the plate.

**OPTION 2 (SCREW BUILD – continued):**

**4)** It may be easier, but not necessary, to remove the fire control group before proceeding.

Level the anchor plate parallel with the receiver top rail using two c-clamps or vise grips and calipers. Be sure to place the clamps where datum "C" next to the center support can be reached with a drill. Drill thru the receiver with the #21 drill supplied at datum "C" using the anchor plate as a drilling guide. Next, move the clamps so that datum "C" next to the rear trunnion rivet can be reached and proceed to drill thru the receiver. Proceed with drilling datum "D" the same way as both datum "C's". (note: be sure all drilled holes line up with the anchor plate)

Once all three holes have been drilled thru with the #21 drill, remove the anchor plate and drill the receiver holes out with the 13/64 inch drill bit supplied.

Using the #10-32 tap supplied, use oil and carefully tap the three datum points on the anchor plate. The holes have been pre-threaded to help start the tap straight.

(for step 4 see figures: 10 & 11)

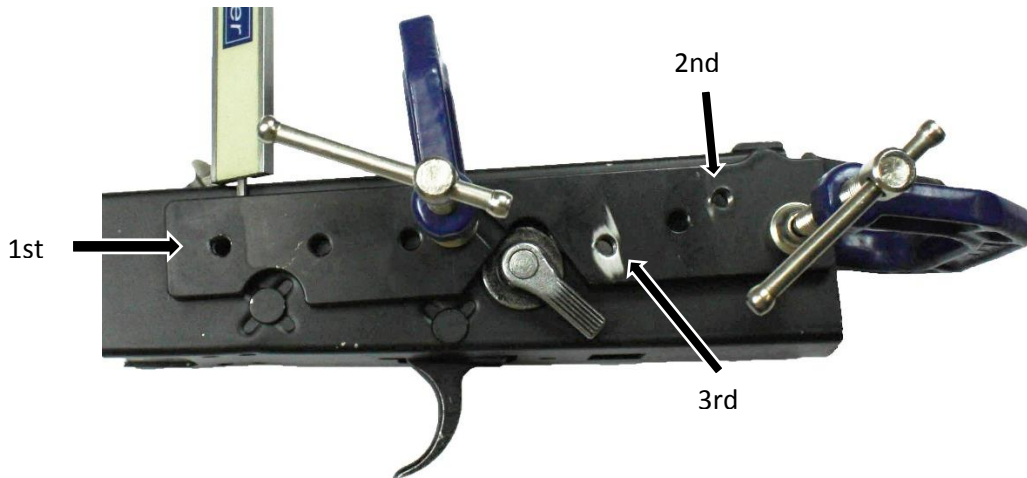

*Figure: 10 leveling the anchor plate to the top rail of the receiver, and drilling the three datum points.*



*Figure: 11 hole placement after drilling with the 13/64 inch drill.*

**OPTION 2 (SCREW BUILD – continued):**

**5)** Do this step if using an original fire control group, otherwise move on to step 6. The build kit came with three button head screws. One of the screws is longer than the other two. The head of the longer screw needs to be ground down in order to clear an original fcg hammer. Take the #10-32 x 5/16 long (the longer one) and grind the head down to approximately 0.280 inch. In a garage setting it is easier to chuck the threads in a hand drill and while spinning the screw in the chuck, grind the edges down on a belt sander or dremel with a sanding drum. (for step 5 see figure: 12)



*Figure: 12 Before and after grinding the head for clearance*

**6)** Align the anchor plate back on the receiver. Start all three #10-32 button head screws to the anchor plate. The longer of the three screws goes next to the center support rivet. Use calipers to re-align the plate parallel with the receiver top rail. Install the fire control group and check for fitment. Make sure all moving parts clear the screw heads. Minor sanding may be needed on the front screw next to the center support. (for step 6 see figures: 13 & 14)



*Figure: 13 Longer screw head ground down to clear hammer*



**OPTION 2 (SCREW BUILD – continued):**

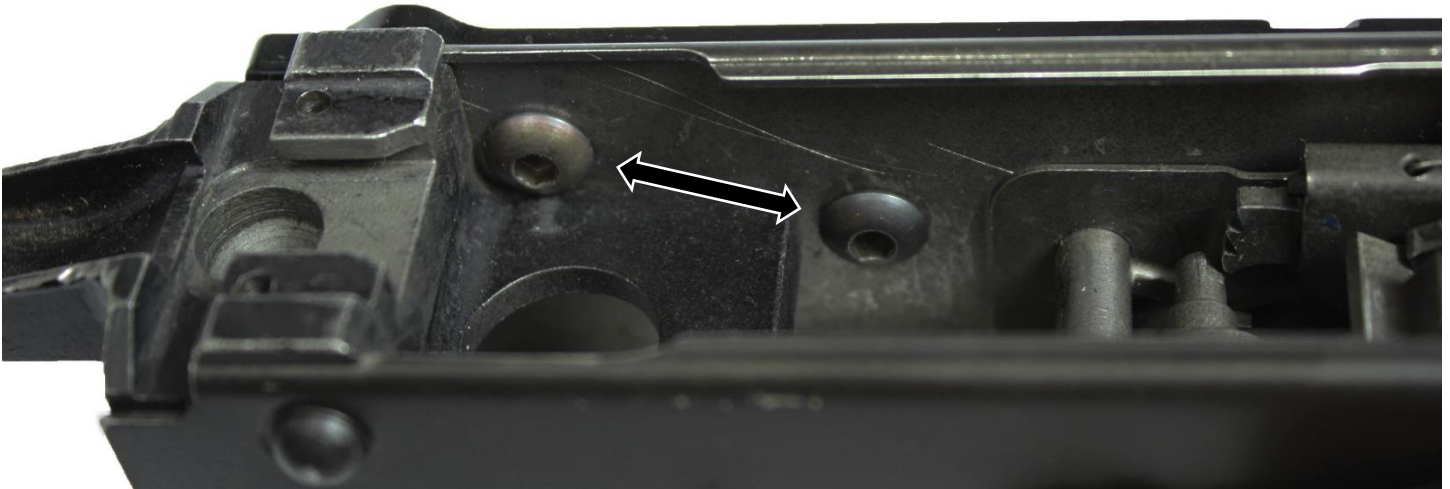

*Figure: 14 rear screw placement*

**7)** If there is any touchup work that needs to be done, now is the time. After alignment and checking fitment of the anchor plate we recommend using red Loctite on the threads of each screw. Do this by replacing each screw one at a time with Loctite to keep the rail aligned. It is also a good idea to “ping” a small divot into the threads from the outside to keep the screws from backing out once all have been replaced with Loctite.  
(for step 7 see figure: 15)



*Figure: 15 “ping” a divot into the screw threads to keep from backing out.*

**OPTION 2 (SCREW BUILD – continued):**

**11)** Finally, lay the dovetail plate on top of the anchor plate and align the datum “E” threaded holes. Tighten the dovetail plate to the anchor plate using the three #10-32 machine screws supplied in the assembly kit. Once the builder is happy with how the mount lays out we suggest using Loctite on the threads and “ping” a small divot on the screw heads using a center punch to keep them from backing off.

(for step 11 see figure : 16)



*Figure : 16 center punched screw heads to keep from backing out*